



TAC Xenta® 280

Controller, Freely Programmable

The TAC Xenta 280 is a family of freely programmable controllers designed for zone control or small-sized heating and air handling systems.

A TAC Xenta 280 controller contains basic HVAC functionality including control loops, curves, time control, alarm handling etc. The TAC Xenta 283 has a LonMark Real Time Keeper object.

The Xenta 280 controller is available with three different I/O configurations, the TAC Xenta 281, 282, and 283. The controllers are designed for cabinet mounting. The controller can be removed/inserted from/to the terminal part without disconnecting the power supply. When adding or replacing a controller it's also possible to pre-configure it in order to achieve Plug and Play functionality without any on-site configurations. They are simple to program and put into operation, using the TAC Menta graphical software tool.

The controller communicates on a LonTalk TP/FT-10 network via a twisted-pair, unpolarized cable. It is able to operate as a stand-alone unit and can be easily connected to a large LonWorks based network.

For local use, the TAC Xenta OP (Operator Panel) can be connected. The operator panel has a display and push buttons for navigating and altering settings. The operator panel can be snapped onto the TAC Xenta controller unit, mounted on the front of the cabinet, or used as a portable terminal.

SYSTEM CONFIGURATIONS

The TAC Xenta 280 controller can be used in different configurations;

- as a stand-alone unit
- as a controller (with operator panel) in a small network
- as a controller (with operator panel) and other equipment in a full network with suitable adapters, possibly connected to a TAC Vista Building Management System

Fig. 1 shows an example of a networked TAC Xenta configuration.

Sensors and actuators on the field level are mostly connected to the conventional inputs/outputs of the controllers.

Some external units, however, may connect directly to the network to communicate input/output data, using Standard Network Variable Types (SNVTs).

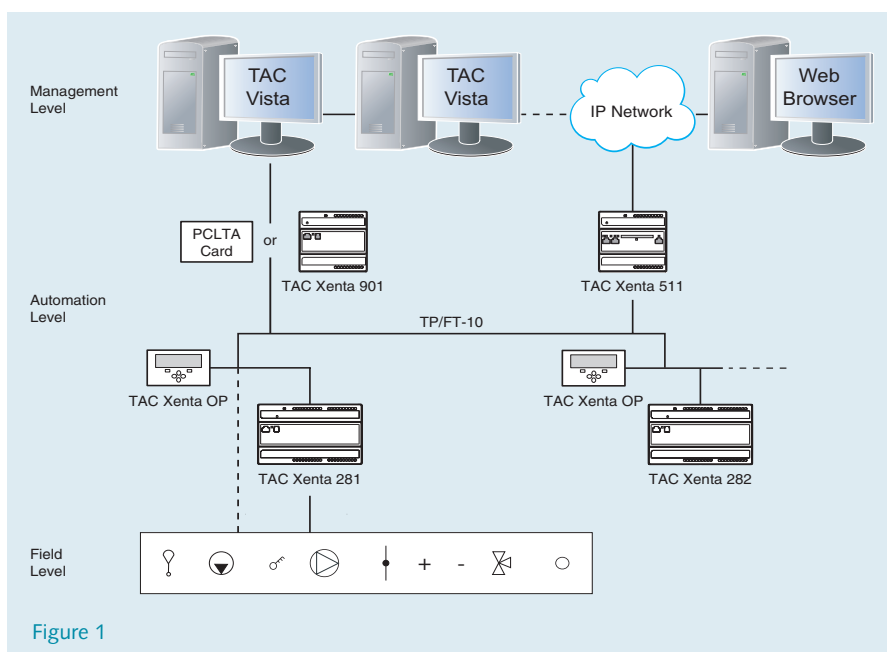

DESIGN

The TAC Xenta 280 controller has been designed as a general purpose unitary (one-to-one) controller. Thus it can be mounted in close proximity to the controlled equipment, minimizing the wiring required.

The TAC Xenta 280 is microprocessor based. It consists of a terminal and electronics mounted together (Fig. 2).

The Xenta 280 can be interfaced with a wide variety of field sensors/transducers and controlled devices. All terminations of field wires are done on the terminal part only. Thus the electronics part may be removed for service without affecting the terminal connections.

Local Operator Panel

The TAC Xenta OP (Operator Panel) is a small operator panel which can be connected to the unit through its enclosure. The operator can read the point status, perform manual override, read measured values, alter set points etc., from the operator panel.

The functions are selected from menus. Access to the unit is enabled by using an access code. It is possible to access other TAC Xenta units on the same network.

Real Time Clock

The clock provides data such as the year, month, date, day, hour, minute and second.

A built-in capacitor guarantees operation of the clock for at least 72 hours in the event of a power outage.

The TAC Xenta 283 is intended to be used as a Real Time Keeper. Real time is exposed as an output network variable, SNVT_time_stamp, which can be bound to other LonWorks devices.

Daylight Saving Time:

European, Australian or USA/Canada

Once set, Daylight Saving Time (DST) is fully automatic. The change-over date and the number of hours to change are programmable. This function can also be disabled.

Digital Inputs

The digital inputs are used to sense alarm contacts, status indications, pulse counting, etc.

Each digital input can be used as a pulse counter (e.g. for flow measurement).

Another application available when using the digital inputs is for alarm monitoring. Each time an alarm is tripped, the corresponding counter can be incremented, providing data for operating statistics. The digital inputs circuits are internally powered.

Universal Inputs

The universal inputs can be individually configured as analog or digital inputs.

A high and a low limit can be set for each universal input. If configured as digital inputs, the universal inputs may be used, for example, for sensing switch positions.

The universal input types are selected via the application program.

Thermistor Inputs

The TAC Xenta 282 and 283 have thermistor inputs, 1.8 k Ω at 25 °C (+77 °F).

In the Xenta 283, these inputs are also individually configurable for 10 k Ω at 25 °C (+77 °F).

Digital Outputs

There are digital outputs for the control of equipment such as fans, pumps or similar devices. The output signal can be

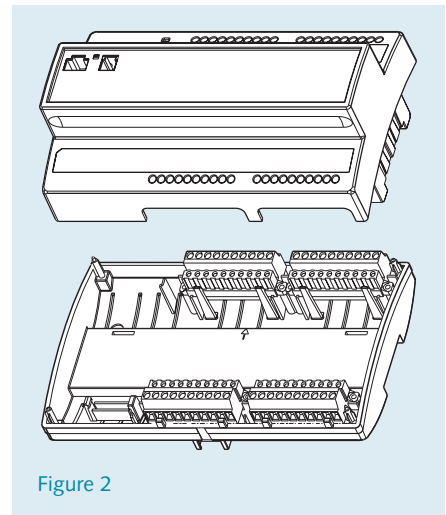

Figure 2

pulse width modulated and can be used to control increase/decrease actuators.

In the TAC Xenta 283, the digital outputs are designed as TRIAC outputs.

Analog Outputs

There are analog outputs for controlling actuators or other analog equipment.

LonWorks SNVT Support

The use of Standard Network Variable Types (SNVT), in accordance with the Echelon specification, makes it possible to communicate with nodes made by other manufacturers.

Power Outage Protection

Using non-volatile (flash) memory, the unit will start up with user settings and work normally after a power outage.

COMMUNICATION

Communication Capabilities

The TAC Xenta 300 has several communication capabilities within a Network with a TAC Vista Building Management System and/or a hand-held operator panel.

LonWorks Connection

TAC Xenta controllers communicate with each other using a common network, LonWorks TP/FT-10, 78 kbps. A number of controllers can form a network and exchange data.

The LonTalk protocol makes it possible to use network variables defined in equipment from third party manufacturers.

The functional block applications are modeled as true LonMark controller objects.

The network variable interface (including the Standard Network Variable Types, SNVTs) can be customized, and external interface files (XIFs) can be generated with the TAC Menta programming tool.

TAC Vista Building Management System

When connected to a TAC Vista Building Management System (version 4.0 or higher, for Xenta 283 version 4.10 or higher), the operating conditions of the fans, pumps, heat exchangers etc. can be monitored in color graphics or printed reports.

Temperatures and alarms can be read, while setpoints and time settings may be altered as required.

TAC Xenta controllers can be reached from TAC Vista in one of the following ways:

- 1 Any controller in the network via a PCLTA card.
- 2 A specific controller via the RS-232 connection.
- 3 Any controller in the network via the TAC Xenta 901 LonTalk adapter.

Application programs generated in TAC Menta may be downloaded from TAC Vista via the network.

TAC Xenta Operator Panel Port

The TAC Xenta OP (Operator Panel) is also connected to the network and can thus act as an operator panel for other units in the network. The connection is made via the modular jack on the front of the controller or directly, using the network cable.

RS-232 Port

The TAC Xenta 280 controller has an RS-232 port. This port is intended for connection to a PC using the TAC Menta programming tool for loading and commissioning the application program.

The port can also be used for connection between TAC Vista and specific TAC Xenta 280 units (see 2 under "TAC Vista Building Management System" above). Connection via a modem is not supported.

TECHNICAL DATA

Supply voltage 24 V AC $\pm 20\%$, 50/60 Hz or 19–40 V DC
 Power consumption max. 5 W
 Transformer sizing 10 VA

Ambient Temperature

Storage $-20\text{ }^{\circ}\text{C}$ to $+50\text{ }^{\circ}\text{C}$ ($-4\text{ }^{\circ}\text{F}$ to $+122\text{ }^{\circ}\text{F}$)
 Operation $\pm 0\text{ }^{\circ}\text{C}$ to $+50\text{ }^{\circ}\text{C}$ ($+32\text{ }^{\circ}\text{F}$ to $+122\text{ }^{\circ}\text{F}$)
 Humidity max. 90% RH non-condensing

Mechanical

Enclosure ABS/PC
 Enclosure rating IP 20
 Flammability class, materials UL 94 5VB
 Dimensions see Fig. 3
 Weight 1.0 kg (2.2 lb)

CPU

CPU 32 bit, 10 MHz, 512 kB flash memory, 128 kB SRAM

Real Time Clock

Accuracy at $+25\text{ }^{\circ}\text{C}$ ($77\text{ }^{\circ}\text{F}$) ± 12 minutes per year
 Power outage protection 72 h

Digital Inputs (Xenta 281, 282, 283: X1–X2)

Voltage across open contact 33 V DC
 Current through closed contact 4 mA
 Pulse input duration min. 20 ms

Universal Inputs (Xenta 281, 282: U1–U4)

– Digital inputs:
 Voltage across open contact 26 V DC
 Current through closed contact 4 mA
 Pulse input duration min. 20 ms
 – Thermistor inputs:
 TAC thermistor sensor 1.8 k Ω at $25\text{ }^{\circ}\text{C}$ ($77\text{ }^{\circ}\text{F}$)
 Measuring range $-50\text{ }^{\circ}\text{C}$ to $+150\text{ }^{\circ}\text{C}$ ($-58\text{ }^{\circ}\text{F}$ to $+302\text{ }^{\circ}\text{F}$)
 – Voltage inputs:
 Input signal 0–10 V DC
 Input resistance 100 k Ω accuracy within 1% of full scale

Sensor Inputs (B1–B2, only TAC Xenta 282)

TAC thermistor sensor 1.8 k Ω at $25\text{ }^{\circ}\text{C}$ ($+77\text{ }^{\circ}\text{F}$)
 Measuring range $-50\text{ }^{\circ}\text{C}$ to $+150\text{ }^{\circ}\text{C}$ ($-58\text{ }^{\circ}\text{F}$ to $+302\text{ }^{\circ}\text{F}$)

Sensor Inputs (B1–B4, only TAC Xenta 283)

TAC thermistor sensor 1.8 k Ω at $25\text{ }^{\circ}\text{C}$ ($+77\text{ }^{\circ}\text{F}$)
 or (individually selectable) 10 k Ω at $25\text{ }^{\circ}\text{C}$ ($+77\text{ }^{\circ}\text{F}$)
 Measuring range $-20\text{ }^{\circ}\text{C}$ to $+120\text{ }^{\circ}\text{C}$ ($-4\text{ }^{\circ}\text{F}$ to $+248\text{ }^{\circ}\text{F}$)

Digital Outputs (relays; Xenta 281: K1–K3, Xenta 282: K1–K4)

Control voltage, relay outputs up to 230 V AC
 Control current, to be protected by max. 10 A fuse max. 2 A

Outputs V1–V6 (TRIAC; TAC Xenta 283 only)

Control voltage max. 30 V AC
 Control current max. 0.8 A
 Total control current max. 3 A

Analog Outputs (Xenta 281: Y1–Y3, Xenta 282: Y1–Y4)

Control voltage 0–10 V DC
 Control current, short-circuit proof max. 2 mA
 Deviation max $\pm 1\%$

Communication

TAC Menta; modem 9600 bps, RS-232, RJ-45
 TAC Vista TP/FT-10, screw terminal
 (also for application program download)
 TAC Xenta OP TP/FT-10, modular jack

LonMark Standard

TAC Xenta 281, 282:
 – Interoperability LonMark Interop. Guidelines v 3.0
 – Application LonMark Functional Profile: Plant Controller
 TAC Xenta 283:
 – Interoperability LonMark Interop. Guidelines v 3.3
 – Application LonMark Funct. Profile: Real Time Keeper

Agency Compliances

Emission: CE EN 61000-6-3, C-Tick, FCC Part 15
 Immunity: CE EN 61000-6-1

Safety:

CE EN 61010-1
 UL 916, C-UL US, Energy Management Equipment
 Open, TAC Xenta 281, 282
 Enclosed, TAC Xenta 283
 Approved for plenum installations
 ETL listing (TAC Xenta 280/230) UL 3111-1, first edition
 CAN/CSA C22.2 No. 1010.1-92

Part Numbers

Electronics part TAC Xenta 281/N/P 007300300
 Electronics part TAC Xenta 282/N/P 007300310
 Electronics part TAC Xenta 283/N/P 007300320
 Terminal part TAC Xenta 280/300 007309010
 Operator panel TAC Xenta OP 007309072
 TAC Xenta: Programming Serial Kit 007309200

TAC XENTA NETWORK AND UNIT PERFORMANCE

No. of TAC Xenta controllers 400
 No. of I/O modules 200
 No. of operator panels 100
 No. of TAC Xenta groups 30
 No. of Xenta controllers per group 30
 No. of subscriptions*
 In max. 15
 Out max. 30
 No. of STR350/351 (non-SNVT mode) 2

Trend Logging in the TAC Xenta 280

Channels 1–50
 Interval 10 s – 530 weeks
 Total logging capacity approx. 650 floating point numbers
 or approx. 1,300 integers
 or approx. 10,000 digital values
 Optimized storage Yes

Time Channels

Time Channels 1

Application Size

Program and data max. 56 kB
 Parameters max. 64 kB

* Subscriptions can utilize Standard Network Variable Types (SNVTs) or TAC Network Variables (TACNVs). These can be combined if the following restrictions are observed: the sum of the TACNV subscriptions and the number of SNVT members (no. of values in structured SNVTs) does not exceed the stated figures.

MOUNTING

The TAC Xenta 280 is cabinet mounted on a TS 35 mm Norm rail EN 50 022.

The controller unit consists of two parts; a terminal part with screw terminals, and electronics with the circuit boards.

To simplify installation, the terminal can be pre-mounted in the cabinet (see Fig. 1).

If the TAC Xenta 280 controller is wall mounted, a wide range of standardized boxes are available.

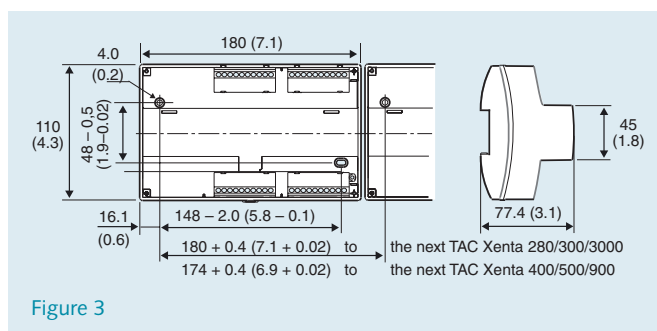

Figure 3

MAINTENANCE

The only care needed is to keep the controller dry and to clean it externally with a dry cloth when needed.

SOFTWARE FEATURES

With the assistance of TAC Menta (4.0 or higher; for Xenta 283 4.10 or higher), a graphical programming tool using Functional Block Diagrams (FBDs), the TAC Xenta 280 may be easily adapted to different control and monitoring tasks.

The basic software includes pre-programmed routines for:

- reading of digital inputs (alarms, pulse counting, interlocks)
- reading of universal inputs (individually selectable as analog or digital)
- control of digital outputs
- control of analog outputs
- on and off delays
- pulse counting (digital inputs only)

- alarm handling; alarm conditions may be detected via the digital or analog inputs
- equipment run time totals on selected objects
- one-time schedule block with 16 entries (start and stop times in hours and minutes): weekly and/or holidays
- programs for optimum start/stop
- control characteristic curves
- outdoor temperature compensating control curves
- PID control loops (loops may be connected in cascade)
- trend logging (max. 5 kB)
- local level operator interface via TAC Xenta OP (Operator Panel)

- network communication according to the LonTalk protocol
- communication with the TAC Vista Building Management System via modem

The basic software is adapted to the current application by connecting pre-programmed functional blocks and by adjusting the relevant parameters. These connections and parameters are stored in non-volatile memory.

The parameters may be changed during ongoing operation either from the TAC Vista Building Management System or locally from the TAC Xenta OP (Operator Panel).

CABLES

G and GO

Min. area 0.75–1.5 mm² (19–16 AWG).

Cable with modular jack for RS-232 serial communication port: Max. 10 m (32 ft).

Terminals X

Min. area 0.25 mm² (23 AWG).

Max. cable length 200 m (650 ft).

Terminals U, B, Y

Min. area 0.25–0.75 mm² (23–19 AWG).

Max. cable length 20–200 m (65–650 ft).

For more details, see the TAC Xenta 280/300/401 Handbook (part no. 0-004-7768).

Terminals K, V

Min. area 0.75–1.5 mm² (19–16 AWG).

Max. cable length 200 m (650 ft).

C1 and C2

TP/FT-10 allows the user to wire the control devices with virtually no topology restrictions. The max. wire distance in one segment depends on the type of wire and the topology, see the table below.

The TAC Xenta Network guide (part no. 0-004-7460) gives a more detailed description.

Cable	Max. bus length, doubly terminated bus topology m (ft)	Max. node-to-node distance, singly terminated free topology m (ft)	Max. length singly terminated free topology m (ft)
Belden 85102, single twisted pair	2,700 (9,000)	500 (1,600)	500 (1,600)
Belden 8471, single twisted pair	2,700 (9,000)	400 (1,300)	500 (1,600)
UL Level IV 22AWG, twisted pair	1,400 (4,600)	400 (1,300)	500 (1,600)
Connect-Air 22AWG, one or two pairs	1,400 (4,600)	400 (1,300)	500 (1,600)
Siemens J-Y(st)Y 2x2x0.8 4-wire helical twist, solid, shielded	900 (3,000)	320 (1,000)	500 (1,600)
TIA568A Cat. 5 24AWG, twisted pair	900 (3,000)	250 (820)	450 (1,500)

I/O CONFIGURATIONS

The Xenta 280 controller is available with three different I/O configurations, the TAC Xenta 281, 282, and 283.

No external I/O modules are used with the TAC Xenta 280.

The table gives an overview of the different numbers of inputs and outputs.

DI, DO: Digital input, output

UI: Universal input

TI: Thermistor input

AO: Analog output

Unit	DI	DO	UI	TI	AO
TAC Xenta 281	2	3	4	–	3
TAC Xenta 282	2	4	4	2	4
TAC Xenta 283	2	6	–	4	–

INSTALLATION

The three TAC Xenta 280 controllers have different inputs and outputs. The adjacent table shows the terminal connections of the three TAC Xenta controllers.

There is a label on the front of the controller with the numbers and the names of the terminals (1 C1, 2 C2 and so on). The numbers are also moulded in the plastic of the terminal part.

Note! The installation of high voltage cables must be performed by qualified personnel!

For detailed information, please refer to the TAC Xenta 280/300/401 Handbook (part no. 0-004-7768).

TAX Xenta Operator Panel

The TAC Xenta operator panel can easily be connected to the network by means of the modular socket on the front of the controller.

LED Indicator

An LED indicator on the electronic unit of the TAC Xenta 280 indicates when the application program is running.

Service Pin

To simplify network commissioning, there is a service pin on the electronic unit which, when pressed, identifies the unit on the network.

Terminal Connections (Inputs)

Term. No.	Term. Name			Description
	281	282	283	
1	C1	C1	C1	LonWorks TP/FT-10
2	C2	C2	C2	LonWorks TP/FT-10
3	U1	U1	-	Universal
4	M	M	M	Msrmnt. neutral
5	U2	U2	-	Universal
6	U3	U3	-	Universal
7	M	M	M	Msrmnt. neutral
8	U4	U4	-	Universal
9	-	B1	B1	Thermistor
10	-	M	M	Msrmnt. neutral
11	-	B2	B2	Thermistor
12	-	-	B3	Thermistor
13	-	M	M	Msrmnt. neutral
14	-	-	B4	Thermistor
15	X1	X1	X1	Digital
16	M	M	M	Msrmnt. neutral
17	X2	X2	X2	Digital
18	-	-	-	
19	M	M	M	Msrmnt. neutral
20	-	-	-	

Terminal Connections (Outputs)

Term. No.	Term. Name			Description
	281	282	283	
21	G	G	G	24 V AC (or DC+)
22	G0	G0	G0	Ground
23	Y1	Y1	-	0-10 V
24	M	M	-	Output neutral
25	Y2	Y2	-	0-10 V
26	Y3	Y3	-	0-10 V
27	M	M	-	Output neutral
28	-	Y4	-	0-10 V
29	-	-	-	
30	-	-	-	
31	-	-	V5	TRIAC out
32	-	-	-	
33	-	-	V6	TRIAC out
34	K1	K1	K1	Relay; TRIAC out
35	KC1	KC1	-	K1, K2 common
36	K2	K2	V2	Relay; TRIAC out
37	K3	K3	V3	Relay; TRIAC out
38	KC2	KC2	-	K3, K4 common
39	-	K4	V4	Relay; TRIAC out
40	-	-	VC	24 V AC, TRIACs